

## Motors and drives

A guide to equipment eligible for  
Enhanced Capital Allowances



# Contents

Introduction	01
Background	01
Setting the scene	02
Benefits of purchasing ETL-listed products	03
Motor and drive equipment eligible under the ECA scheme	03
Single speed motors	03
Variable Speed Drives	04
Integrated motor drives	05
Switched reluctance drives	06
Calculating the payback of your investment	08

## Introduction

ECAs are a straightforward way for a business to improve its cash flow through accelerated tax relief. The scheme encourages businesses to invest in energy saving plant or machinery specified in the ETL to help reduce carbon emissions, which contribute to climate change.

The Energy Technology List (ETL) is a register of products that may be eligible for 100% tax relief under the Enhanced Capital Allowance (ECA) scheme for energy saving technologies<sup>1</sup>. The Carbon Trust manages the list and promotes the ECA scheme on behalf of government.

This leaflet gives an overview of motors and drives specified on the ETL and aims to help businesses present a sound business case for purchasing energy saving equipment from ETL manufacturers and suppliers.

### Further information

For more information please visit [www.carbontrust.co.uk/motors](http://www.carbontrust.co.uk/motors) or download the Carbon Trust's *Motors* technology overview (CTV016) or the *Variable speed drives* technology guide (CTG006).

## Background

The ETL comprises two lists: the Energy Technology Criteria List (ETCL) and the Energy Technology Product List (ETPL). The ETCL defines the performance criteria that equipment must meet to qualify for ECA scheme support; the ETPL is a qualified list of products that have been assessed as being compliant with ETCL criteria.

<sup>1</sup> Eligibility for ECAs is based on a number of factors. Visit [www.eca.gov.uk/energy](http://www.eca.gov.uk/energy) to find out more.

## Setting the scene

An electric motor is a device for converting electrical energy to rotary kinetic (movement) energy in order to power a process such as a pump, fan or conveyor. Motors can be found in the vast majority of equipment, for example:

- The fans that provide combustion air for gas to burn in a heating system
- The pumps that deliver the hot water to the heating systems radiators
- The prime mover in an air compressor
- The device that drives a conveyor belt in a production line.

Electric motive power is likely to form a large part of an organisation's energy consumption. The industrial use of electric motor power accounts for almost two-thirds of the entire industrial electricity consumption in the UK<sup>2</sup>. This amounted to some 77.7 teraWatt hours (TWh) in 2004, which is equivalent to around 33.4 million tonnes of CO<sub>2</sub> emitted to the atmosphere<sup>3</sup> (TWh = 10<sup>12</sup> Watts).

The energy consumed by a motor and drive system can be seen in the diagram below. For every unit of energy (kWh) supplied to a system containing a variable speed drive (VSD), motor and gearbox, 5% is lost in the VSD and around 8% in the motor. In this example only around 77% of the energy supplied to the system is converted into useful movement at the load.

Energy savings can be achieved for motors and drives by purchasing and installing energy efficient ETL-listed equipment.

### Did you know?

In an average year, a central heating pump can cause 141.9kg CO<sub>2</sub> to be released into the atmosphere.

(Assume a heating pump consuming 110Watts for 3000 hrs per year = 330kWh = 38.6kg carbon).

**Figure 1** Typical system losses

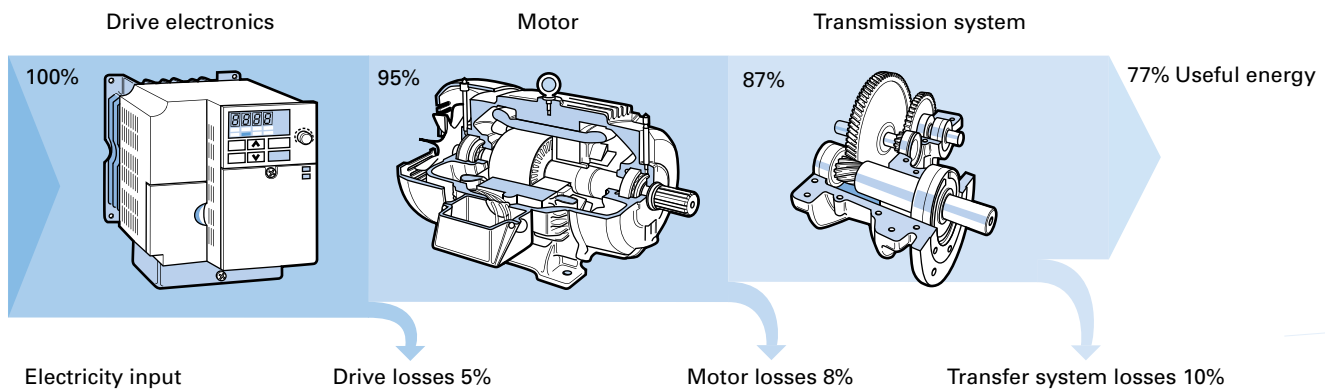

<sup>2</sup> The Carbon Trust's *Motors and drives* technology overview (CTV016).

<sup>3</sup> The Carbon Trust's *Motors and drives* technology overview (CTV016).

## Benefits of purchasing ETL-listed products

Motor and drive products listed on the ETL are highly energy efficient, particularly when compared to older versions of the same technology.

When replacing equipment, businesses are often tempted to opt for that with the lowest capital cost; however, such immediate cost savings can prove to be a false economy. Considering the life cycle cost before investing in equipment can help reduce costs and improve cash flow in the longer term.

The ECA scheme provides businesses with 100% first year tax relief on their qualifying capital expenditure. This means that businesses can write off the whole cost of the equipment against taxable profits in the year of purchase. This can provide a cash flow boost and an incentive to invest in energy saving equipment which normally carries a price premium when compared to less efficient alternatives.

Using this leaflet you can calculate the benefits of investing in ECA-qualifying energy saving equipment over non-qualifying equipment. The calculation includes the benefits of accelerated tax relief, reduced running costs, increased efficiency, lower energy bills and reduced Climate Change Levy payments (if applicable), which in turn helps reduce payback periods.

### Did you know?

An 11kW ETPL-listed motor uses almost £140 less energy per year than a non-listed model<sup>4</sup>.

### Important

Businesses purchasing equipment must check the ETPL at the time of purchase in order to verify that the named product they intend to purchase is designated as energy saving equipment. Motor and drive equipment that meets the ETL eligibility criteria but is not listed on the Energy Technology Product List (ETPL) at the time of purchase is *not* eligible for an ECA.

## Motor and drive equipment eligible under the ECA scheme<sup>5</sup>

### Single speed motors

Fixed speed caged induction motors are single speed motors (SSMs) which use conventional alternating electric current (AC) to induce a force (torque) on their rotor, causing it to rotate.

The diagram below shows the components of a fixed speed caged induction motor. As electrical power is applied to the motor, a rotating magnetic field is created around the stator (1). This induces currents and associated magnetic fields in the rotor (2), causing the rotor and shaft (3) to spin. The shaft is mounted on bearings (4) and is able to rotate freely.

**Figure 2** Fixed speed caged induction motor

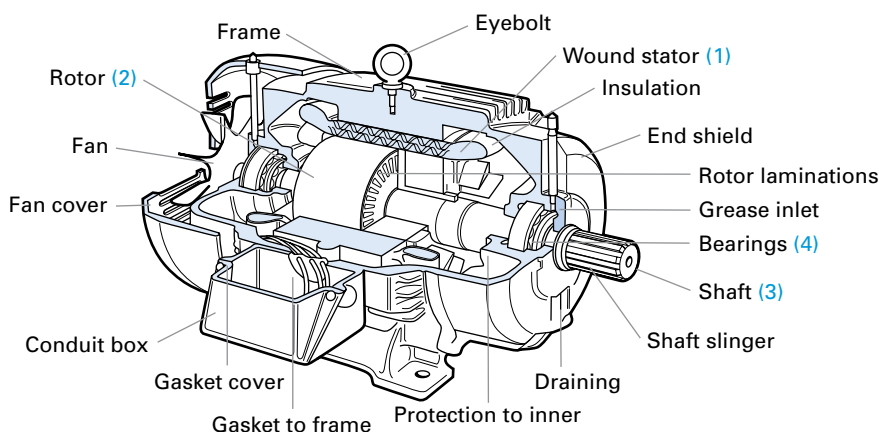

<sup>4</sup> Source: *Motors and drives* technology overview (CTV016) substituting the words 'ETPL-listed' for 'High Efficiency Motors (HEM)' and 'non-listed' for 'EFF2'.

<sup>5</sup> The descriptions of the motors and drives equipment given in this leaflet are examples only. The formal criteria and details governing the ECA scheme can be found at [www.eca.gov.uk/energy](http://www.eca.gov.uk/energy).

SSMs eligible under the ECA scheme are fixed speed three-phase caged induction motors, which operate from a supply voltage of between 200V and 750V at a frequency of 50Hz. These motors must have a minimum efficiency level which depends on the kW rating and the number of poles the motor has. The number of poles in a motor relates to the rated fixed speed of the motor.

Using the baseline scenario below, the potential financial (£), energy (kWh) and carbon savings (tonnes CO<sub>2</sub>) have been calculated for installing ETL-specified SSM equipment.

Baseline scenario:

- One new 22kW 4-pole motor which has an efficiency of 93%.
- This is replacing a 22kW 4-pole motor which has previously been rewound and has an efficiency of 81%.
- The loading of the motor is assumed to be 85% and is running continuously for 24 hours per day, 365 days per year.
- Electricity unit price is 7.9 p/kWh.

By installing a single 22kW ETPL-listed SSM the potential annual savings are calculated as:

- £2,062
- 26,095kWh
- 11.2 tonnes CO<sub>2</sub>

### Did you know?

Using a VSD to slow down a fan or pump motor from 100% to 80% can save as much as 50% on energy use<sup>6</sup>.

## Variable speed drives

Electric induction motors run at fixed speeds and are ideally suited to applications where a constant motor output speed is required, for example a conveyor. However, there are some applications where varying motor output speeds are preferable, for example, fans, pumps, winders and precision tools.

A variable speed drive (VSD), (also known as a frequency converter, adjustable speed drive or inverter), is an electronic device that controls the characteristics of a motor's electrical supply. Therefore, it is able to control the speed and torque of a motor, achieving a better match with the process requirements of the machine it is driving. For applications where variable control is desirable, slowing down a motor with a VSD can reduce energy use substantially.

A VSD works by converting the incoming electrical supply of fixed frequency into a variable frequency output. This variation in frequency allows the drive to control the way in which the motor operates — a low frequency for a slow speed and a higher frequency for a faster speed. The output can also be changed to enable the motor to generate more or less torque as required. The motor and drive combination can be used for turning a large load at relatively slow speeds, or turning a lighter load at high speeds, thereby maximising efficiency.

**Figure 3** A typical variable speed drive

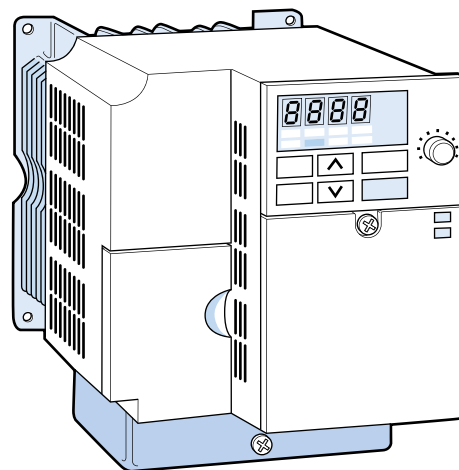

<sup>6</sup> Source: The Carbon Trust's *Variable speed drives* technology guide (CTG006).

VSDs listed on the ETPL are able to vary the speed of an SSM by generating a variable frequency, three-phase power output. This can be matched to the torque-speed characteristics of the driven load, including both loads with a quadratic torque-speed and linear torque-speed characteristics. Put simply, this means that the VSD should be able to drive a motor connected to either a conveyor or one that is connected to a pump.

As a minimum, ETPL-listed VSDs are able to vary the speed of a connected SSM by between 100% and 50% of the motor's maximum continuous speed rating.

Using the baseline scenario below, the potential financial (£), energy (kWh) and carbon savings (tonnes CO<sub>2</sub>) have been calculated for installing ETL-specified VSD equipment.

Baseline scenario:

- One new 22kW 4-pole motor which has an efficiency of 93%.
- This is replacing a 22kW 4-pole motor which has previously been rewound and has an efficiency of 81%.
- The loading of the motor is assumed to be 85% and is running continuously for 24 hours per day, 365 days per year.
- Electricity unit price is 7.9 p/kWh.
- The 22kW motor drives a centrifugal pump which runs continuously circulating water around a closed loop.
- The motor is 85% loaded.
- The motor is 93% efficient and the VSD is 95% efficient.
- The speed of the pump can be reduced by 20% without any noticeable reduction in the performance of the water system.

By installing a single VSD onto a 22kW pump, the potential annual savings are calculated as:

- £6,767
- 85,661kWh
- 36.8 tonnes CO<sub>2</sub>

## Integrated motor drives

A fast expanding market is that of a motor and VSD attached piggy-back style in a combined package. These are called integrated motor drives (IMD) but can sometimes be referred to as smart motors. IMDs have several advantages over separate units, including:

- Lower total cost
- Reduced wiring time
- No electromagnetic interference emissions from the motor side inverter leads, cables or cabling
- Optimum matching of the motor to the VSD.

IMDs are typically used in the pump market, where pump manufacturers can utilise the ability to reduce the speed of a pump, and therefore supply one package comprising pump, motor and drive.



Image supplied courtesy of Brook Crompton UK.

### Note

For the purposes of ETPL listing, the IMD *must* have a separate part number from that of the pump.

IMDs eligible under the ECA scheme are able to vary the speed of the attached SSM by generating a variable frequency, three-phase power output that can be matched to the torque-speed characteristics of the driven load, including both loads with quadratic torque-speed and linear torque-speed characteristics. Put simply, this means that the IMD should be able to drive a motor connected to either a conveyor or one that is connected to a pump.

As a minimum, ETPL-listed IMDs are able to vary their speed by between 100% and 50% of their maximum continuous speed rating.

Using the baseline scenario below, the potential financial (£), energy (kWh) and carbon savings (tonnes CO<sub>2</sub>) have been calculated for installing ETL-specified IMD equipment.

Baseline scenario:

- One new 22kW 4-pole motor which has an efficiency of 93%.
- This is replacing a 22kW 4-pole motor which has previously been rewound and has an efficiency of 81%.
- The loading of the motor is assumed to be 85% and is running continuously for 24 hours per day, 365 days per year.
- Electricity unit price is 7.9 p/kWh.
- The 22kW motor drives a centrifugal pump which runs continuously, circulating water around a closed loop.
- The motor is 85% loaded.
- The motor is 93% efficient and the VSD is 95% efficient.
- The speed of the pump can be reduced by 20% without any noticeable reduction in the performance of the water system.

By installing a single IMD to replace a 22kW pump motor, the potential annual savings are calculated as:

- £6,767
- 85,661kWh
- 36.8 tonnes CO<sub>2</sub>

## Switched reluctance drives

Switched reluctance drives (SRDs) comprise a special motor (switched reluctance) and associated drive electronics.

A switched reluctance (SR) motor is a rotating electric device in which both stator (the fixed part) and rotor (the rotating part) have salient poles. Salient poles are constructed in such a way that each pole provides from the sector. This focuses the magnetic flux into discrete areas of the motor, which maximises its efficiency. The stator winding is comprised of a set of coils, each of which is wound on one pole. SR motors differ in the number of phases wound on the stator. Each one has a certain number of suitable combinations of stator and rotor poles.

The SR motor is driven by a sequence of current pulses applied at each phase. The individual phases are consequently excited, forcing the motor to rotate. These current pulses are applied to the respective phase at the exact rotor position relative to the excited phase. The profile of the phase current together with the magnetisation characteristics defines the generated torque, and thus the speed of the motor.

**Figure 4** Operation of an SR motor

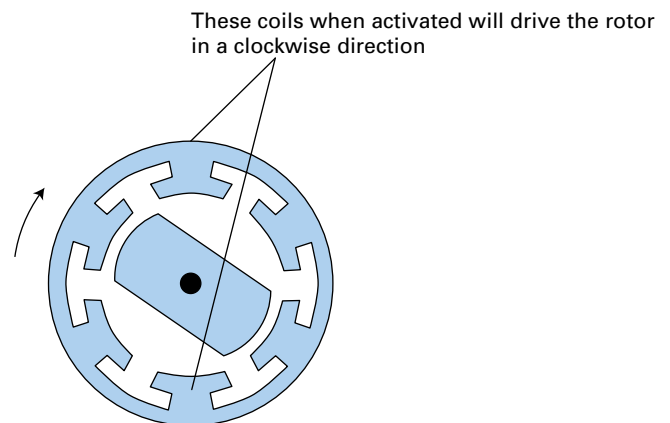

### Did you know?

SRDs can run at a high efficiency over a wide range of speed and torque.



SRDs on the ETPL generate a variable frequency output suitable for varying the speed of an SR motor. They are able to be connected directly to the public electricity supply system in the UK or any nominally fixed frequency and voltage AC supply.

As a minimum, ETPL-listed SRDs are able to vary their speed by between 100% and 20% of their maximum continuous speed rating.

Using the baseline scenario below, the potential financial (£), energy (kWh) and carbon savings (tonnes CO<sub>2</sub>) have been calculated for installing ETL-specified SRD equipment.

Baseline scenario:

- One new 22kW 4-pole motor which has an efficiency of 93%.
- This is replacing a 22kW 4-pole motor which has previously been rewound and has an efficiency of 81%.
- The loading of the motor is assumed to be 85% and is running continuously for 24 hours per day, 365 days per year.
- Electricity unit price is 7.9 p/kWh.
- The 22kW motor drives a centrifugal pump which runs continuously circulating water around a closed loop.
- The motor is 85% loaded.
- The motor is 93% efficient and the VSD is 95% efficient.

- The speed of the pump can be reduced by 20% without any noticeable reduction in the performance of the water system.
- The SRD is replacing a fixed speed 22kW pump motor which is 82% efficient and runs at 85% load.
- The motor runs for 2,500 hours per year.
- The SRD is 95% efficient and the pump's speed can be reduced by 20% whilst still maintaining the same system performance of the load.

By installing an SRD to replace a 22kW motor, the potential annual savings are calculated as:

- £2,607
- 33,000kWh
- 14.2 tonnes CO<sub>2</sub>

#### Information for purchasers

For further information about the ECA scheme, the Energy Technology List (ETL) and other Technology Information Leaflets in the series please visit [www.carbontrust.co.uk/eca](http://www.carbontrust.co.uk/eca), contact the Carbon Trust on 0800 085 2005 or email [customercentre@carbontrust.co.uk](mailto:customercentre@carbontrust.co.uk)

## Calculating the payback of your investment

Based on the operating conditions above, indicative savings can be calculated for replacing your existing equipment with either ETL-listed equipment or non-ETL-listed equipment.

The accelerated tax relief and cash flow benefit provided by the ECA, together with the life cycle cost savings from ETL-listed equipment, aid in bridging the price premium and shortening the investment payback period<sup>7</sup>.

To calculate the payback period for ETL-listed equipment and non-ETL-listed equipment for comparison you will need:

- The unit price (kWh) of the fuel your business consumes.
- Estimated fuel usage (kWh) for the ETL proposed equipment solution(s), which the manufacturer or supplier should be able to help you with.
- Estimated fuel usage (kWh) for the non-ETL proposed equipment solution(s), which the manufacturer or supplier should be able to help you with.
- Estimated annual maintenance costs incurred by your business for the ETL-listed equipment (your manufacturer or supplier should be able to help you with estimates).
- Estimated annual maintenance costs incurred by your business for the non-ETL-listed equipment (your manufacturer or supplier should be able to help you with estimates).
- The value of the proposed capital expenditure.
- Your business's corporation tax rate.

In addition, the following information is also required:

- A copy of the Carbon Trust fact sheet *Energy and carbon conversion* (CTL004).
- Incorporation of the fact that capital allowance (CA) tax relief for non ETL equipment is 20% and that enhanced capital allowance (ECA) tax relief for ECA equipment is 100%.

**Step 1:** To prepare your business case for investment you first need to estimate annual energy consumption of the ETL-listed equipment and non-ETL-listed equipment.

$$\text{Annual energy consumption (kWh/y)} = \text{Equipment consumption (kW)} \times \text{Number of operating hours/year}$$

Additionally, you can calculate the carbon emissions associated with the energy consumption using either the Carbon Trust fact sheet *Energy and carbon conversion* (CTL004) or by using the tool at [www.carbontrust.co.uk/conversionfactors](http://www.carbontrust.co.uk/conversionfactors) by simply multiplying the energy consumption by the carbon emission factor for that fuel type.

$$\text{Carbon emissions} = \text{Annual energy consumption (kW)} \times \text{Emission factor (kg CO}_2\text{/kWh)}$$

**Step 2:** Calculate the annual running cost (ARC) of ETL-listed equipment and non-ETL-listed equipment.

$$\text{ARC} = \text{Annual energy consumption (kW)} \times \text{Pence/kWh} + \text{Annual maintenance cost}$$

Step 1 and 2 can also be done for your existing equipment to calculate an ARC, in order to allow comparisons of the annual saving (step 3) between the existing equipment, the ETL-listed equipment, and the non-ETL-listed equipment.

**Step 3:** Calculate the annual saving between the ETL-listed annual running costs and non-ETL-listed annual running costs.

$$\text{Annual saving} = \text{ARC of ETL listed equipment} - \text{ARC of ETL non-listed equipment}$$

**Step 4:** Calculate the tax allowance for ETL-listed equipment and non-ETL-listed equipment which will be business-specific based on the following:

- The value of your capital expenditure
- Capital allowance (CA) tax relief for non-ETL equipment is 20%
- Enhanced capital allowance (ECA) tax relief for ECA equipment is 100%
- The rate of corporation or income tax for your business.

<sup>7</sup> The values used in the examples given are for illustrative purposes only and do not reflect specific case studies. Anyone considering purchasing this type of equipment would be advised to also analyse the benefits that would be available based on their own circumstances. It should also be noted that the use of formally trained motors and drives equipment technicians can provide significant energy saving benefits.

$$\text{CA tax allowance} = \text{Capital expenditure} \times 20\% \times \text{Rate of corporation tax}$$

$$\text{ECA tax allowance} = \text{Capital expenditure} \times 100\% \times \text{Rate of corporation tax}$$

**Step 5:** Calculate the pay back for ETL-listed equipment and non-ETL-listed equipment.

$$\text{Payback period} = \frac{\text{Tax allowance} + \text{Annual saving}}{\text{Capital expenditure}}$$

To calculate the available CA tax allowance on capital expenditure beyond Year 1 you need to decrease the capital expenditure by 20% per year on a reducing balance basis. Over the nine years the available CA tax allowance are shown in the table below.

**Table 1** The cash flow boost to your business of an ECA over a CA for a capital investment of £10,000

	Year								
	1	2	3	4	5	6	7	8	9
Capital Expenditure (£)	10,000	8,000	6,400	5,120	4,096	3,277	2,621	2,097	1,678
Capital Allowance (CA) @ 20% (£)	2,000	1,600	1,280	1,024	819	655	524	419	336
CA Tax Allowance	560	448	358	287	229	184	147	117	94
Enhanced Capital Allowance @100% (£)	10,000	0	0	0	0	0	0	0	0
ECA Tax Allowance	2,800	0	0	0	0	0	0	0	0

Calculations are based on 28% corporation tax

# Go online to get more

The Carbon Trust provides a range of tools, services and information to help you implement energy and carbon saving measures, no matter what your level of experience.

**Carbon Footprint Calculator** – Our online calculator will help you calculate your organisation's carbon emissions.

—▶ [www.carbontrust.co.uk/carboncalculator](http://www.carbontrust.co.uk/carboncalculator)

---

**Interest Free Loans** – Energy Efficiency Loans from the Carbon Trust are a cost effective way to replace or upgrade your existing equipment with a more energy efficient version. See if you qualify.

—▶ [www.carbontrust.co.uk/loans](http://www.carbontrust.co.uk/loans)

---

**Carbon Surveys** – We provide surveys to organisations with annual energy bills of more than £50,000\*. Our carbon experts will visit your premises to identify energy saving opportunities and offer practical advice on how to achieve them.

—▶ [www.carbontrust.co.uk/surveys](http://www.carbontrust.co.uk/surveys)

---

**Action Plans** – Create action plans to implement carbon and energy saving measures.

—▶ [www.carbontrust.co.uk/apt](http://www.carbontrust.co.uk/apt)

---

**Case Studies** – Our case studies show that it's often easier and less expensive than you might think to bring about real change.

—▶ [www.carbontrust.co.uk/casestudies](http://www.carbontrust.co.uk/casestudies)

---

**Events and Workshops** – The Carbon Trust offers a variety of events and workshops ranging from introductions to our services, to technical energy efficiency training, most of which are free.

—▶ [www.carbontrust.co.uk/events](http://www.carbontrust.co.uk/events)

---

**Publications** – We have a library of free publications detailing energy saving techniques for a range of sectors and technologies.

—▶ [www.carbontrust.co.uk/publications](http://www.carbontrust.co.uk/publications)

---

## Need further help?



### Call our Customer Centre on 0800 085 2005

Our Customer Centre provides free advice on what your organisation can do to save energy and save money. Our team handles questions ranging from straightforward requests for information, to in-depth technical queries about particular technologies.

**The Carbon Trust was set up by Government in 2001 as an independent company.**

**Our mission is to accelerate the move to a low carbon economy by working with organisations to reduce carbon emissions and develop commercial low carbon technologies.**

We do this through five complementary business areas:

**Insights** – explains the opportunities surrounding climate change

**Solutions** – delivers carbon reduction solutions

**Innovations** – develops low carbon technologies

**Enterprises** – creates low carbon businesses

**Investments** – finances clean energy businesses.

[www.carbontrust.co.uk](http://www.carbontrust.co.uk)

0800 085 2005

The Carbon Trust is funded by the Department for Environment, Food and Rural Affairs (Defra), the Department for Business, Enterprise and Regulatory Reform, the Scottish Government, the Welsh Assembly Government and Invest Northern Ireland.

Whilst reasonable steps have been taken to ensure that the information contained within this publication is correct, the authors, the Carbon Trust, its agents, contractors and sub-contractors give no warranty and make no representation as to its accuracy and accept no liability for any errors or omissions. Any trademarks, service marks or logos used in this publication, and copyright in it, are the property of the Carbon Trust. Nothing in this publication shall be construed as granting any licence or right to use or reproduce any of the trademarks, service marks, logos, copyright or any proprietary information in any way without the Carbon Trust's prior written permission. The Carbon Trust enforces infringements of its intellectual property rights to the full extent permitted by law.

The Carbon Trust is a company limited by guarantee and registered in England and Wales under Company number 4190230 with its Registered Office at: 8th Floor, 3 Clement's Inn, London WC2A 2AZ.

Printed on paper containing a minimum of 75% recycled, de-inked post-consumer waste.

Published in the UK: August 2008.

© Queen's Printer and Controller of HMSO

ECA764

