

Highline Fitting Instructions

T100 & T150 Chain Opener

1. Fix the chain base to the vertical leg of the window frame with the 2 No M5 machine screws provided (D). Alternatively surface fix with the T740, T750 or T760 brackets (supplied separately) to aluminium, PVC-U or timber windows respectively or if fixing to bottom hung open in window, use T850 bottom hung fixing kit (see drawings at the bottom of page).
2. Fit the vent bracket with the 2 No 12mm screws supplied (E) or use other screws appropriate to vent material. Be careful not to break the glass.
3. Unfasten screws (A) & (B) and remove the locking pin from the top of the chain opener. Remove the chain body from the chain base and put to one side with the screws and pin.
4. Locate the pre-prepared conduit into the collared slots on either side of the chain base (see T400 instructions for preparing conduit). A length of "spent travel" conduit must be fitted to the last chain opener.
SPENT TRAVEL CONDUIT:
300mm minimum for T100
450mm minimum for T150.
5. Fix the chain body to the chain base with the 2 No. 25mm machine screws "A". Do not replace screw (B) or locking pin (C) at this stage.
6. Wind the cable from the operator through the conduit and the chain base(s) ensuring that the cable moves freely through the conduit.
7. Cut the cable to length allowing an extra 280mm cable for T100 or 410mm cable for T150.
8. Push the vent open with your hand and attach the chain bracket to the vent bracket. Ensure the spring catch is secure.
9. Pull the vent tightly shut with your hand and insert the locking pin (C) into vacant slot on the keyway situated on top of the chain body. Open and close the vent with the operator to check compression of sash and frame. Repeat operation placing pin in adjacent slot should you require further adjustment. Finally fasten locking pin with the 1 No. 12mm machine screw (B).

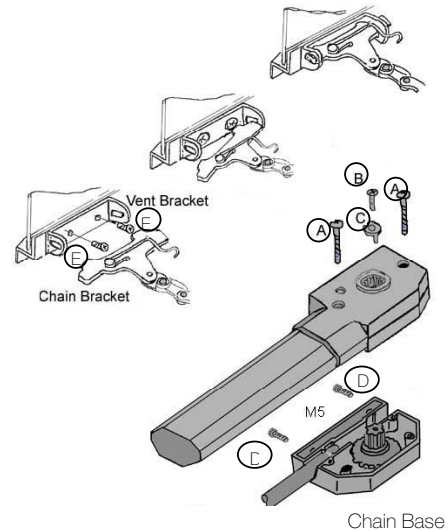

T740 Narrow Fixing Plate	T750 Wide Fixing Plate	T760 Angled Fixing Plate	T850 Bottom-Hung Fixing Kit
For surface fixing the chain opener to aluminium windows. Available in white, black or grey.	For surface fixing chain opener to PVCu windows. Available in white, black or grey.	For surface fixing chain opener to timber window sills. Available in white, black or grey.	Set of frame and vent brackets for fitting chain openers to bottom hung, open in windows. Available in white, black or grey.
T740	T750	T760	T850